

# DCCBD

## DCC Current-Based Train Detector

For use with DCC Controlled Layouts

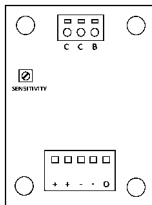

## Introduction to the DCCBD

The DCCBD is a current-based train detector for use with signalling and any other application which requires knowing when a train is within a section of track. The DCCBD relies on Digital Command Control (DCC) signals being present on the track to function correctly.

## Installing the DCCBD

Signalogic Systems recommends a good quality 12VDC accessory power supply and 20-26 AWG solid wire for connections to all devices including the DCCBD. Solid wire telephone and network cabling is a cost effective solution. Ensure that track power and the 12VDC power are off during installation and check wiring prior to turning power back on.

Because DCCBDs are often installed with other DCCBDs, the board has been designed to allow jumper connections between adjacent DCCBD boards for common accessory and track power connections between boards. See Figure 2.

A three terminal connector is provided for connecting the track wiring to the DCCBD:

B	BLOCK	Wire this terminal to the track being detected.
C	DCC COMMON BUS	Wire this terminal to the DCC bus. There are two common terminals, allowing daisy-chaining of the DCC common buss between DCCBD boards.

The DCCBD has a five pin terminal for powering and interfacing the DCCBD:

+	12VDC	Positive power input. There are two + terminals, allowing the daisy-chaining of power between DCCBD boards.
-	GND	Negative power input. There are two - terminals, allowing the daisy-chaining of power between DCCBD boards.
O	OUTPUT	Detection output. Open-circuit with no train, connected to GND when a train is detected.

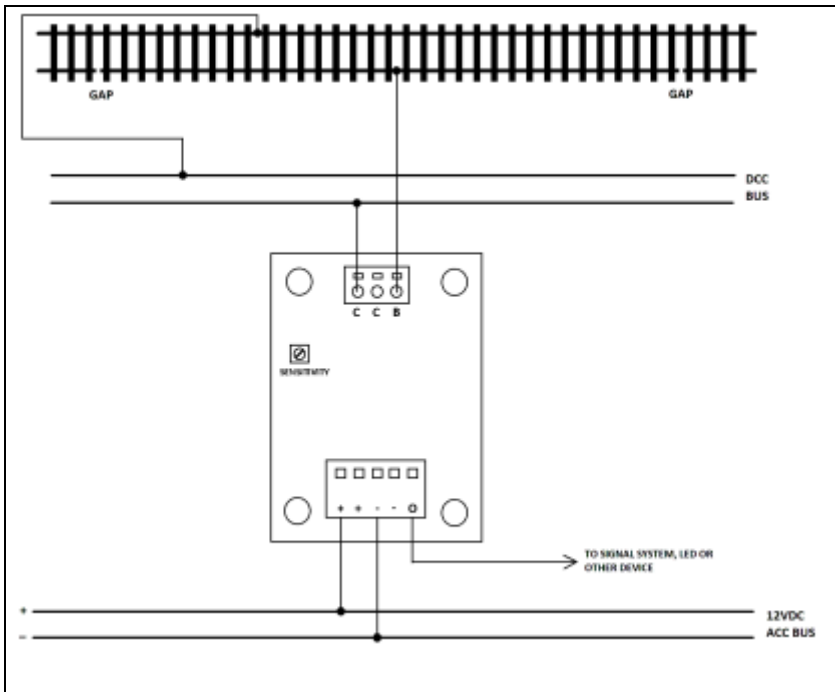

Figure 1 - Basic Connections

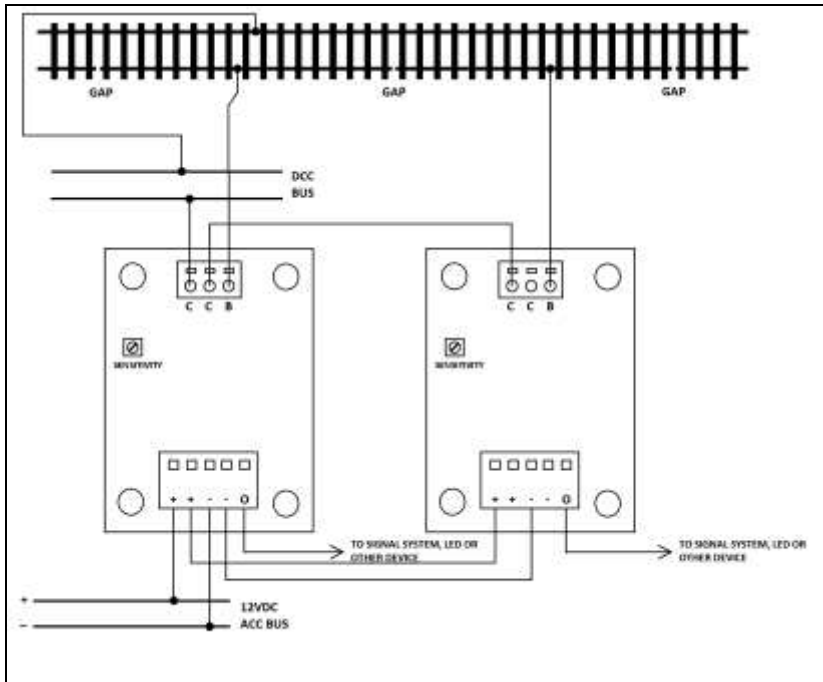

Figure 2 - Connecting Multiple DCCBDs Together

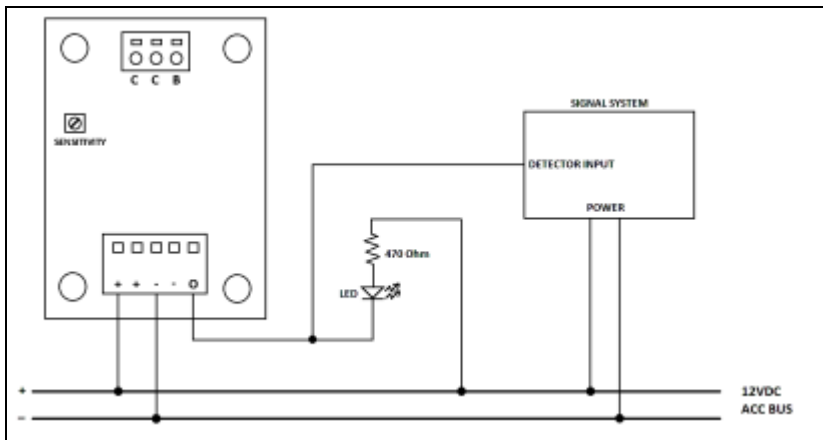

Figure 3 - Example Output Terminal Connections

# Operation

## *Adjustment*

If the DCCBD detects a train when there isn't one, there may be too much leakage current across the rails from ballast and moisture and/or capacitance from wiring and the rails themselves. This effect can be countered by using the adjustment dial on the board to change the sensitivity threshold of the DCCBD.

NOTE: If the DCCBD still falsely detects a train even after setting the adjustment dial to the least sensitive position, double check that there are no other conduction paths to the track, including other feeder wires or bridged rails at block boundary gaps. If that doesn't work, try shortening the block length to see if leakage current loading is the cause.

## Occupancy Indication

When the DCCBD detects current, the onboard LED will illuminate. The LED may flicker with dirty wheels or when the sensitivity is set close to the occupancy level. Occupancy status is output from the DCCBD via the 'O' terminal. The detector will connect this terminal to ground when a train is detected. There is a built-in timer that will keep the 'O' terminal in the occupied state for three seconds after the last current draw is detected. This is similar to 'Loss of Shunt' timers used by real railroads and will help to keep your occupancy status prototypically steady.

### Maximum Specifications

Minimum Power Voltage	10 VDC
Maximum Power Voltage	16 VDC
Maximum Output Current	25 mA
Maximum Block Current	5 A
Maximum Block Capacitance	1 nF

## **Signalogic Systems**

15623 112 Avenue NW  
Edmonton, AB T5M 2V8  
Canada

Ph: 587-520-5390  
Email: [sales@signalogicsystems.com](mailto:sales@signalogicsystems.com)